

# LIBE

mesita de noche en escalera 2 alturas  
table de chevet escalier 2 hauteurs  
mesa de cabeceira em escada 2 alturas

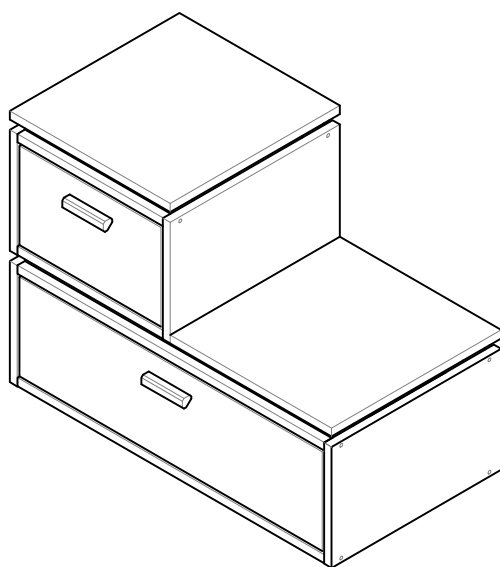

Libe módulo cajón 39x30 x1

---

BH23-004 x1

---

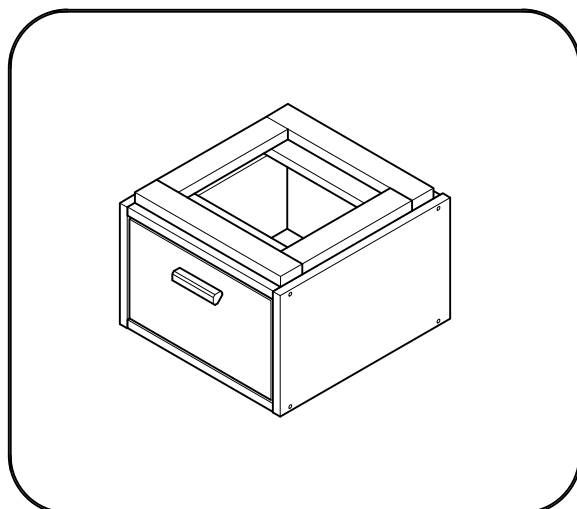

Libe módulo cajón 78x30 x1

---

BH23-004 x1

---

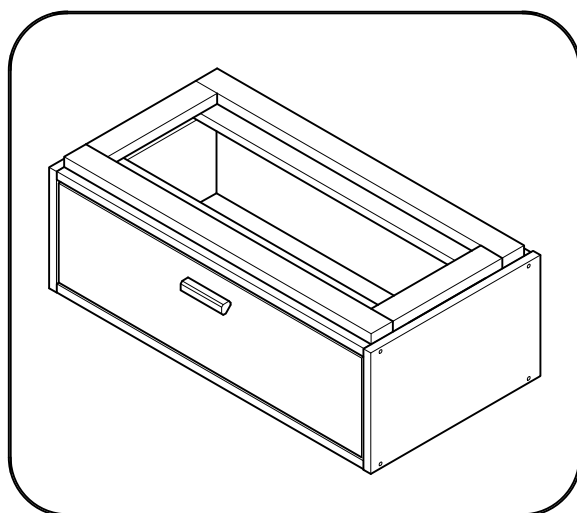

Libe encimera 78 x2

---

BH20-036 x2

---

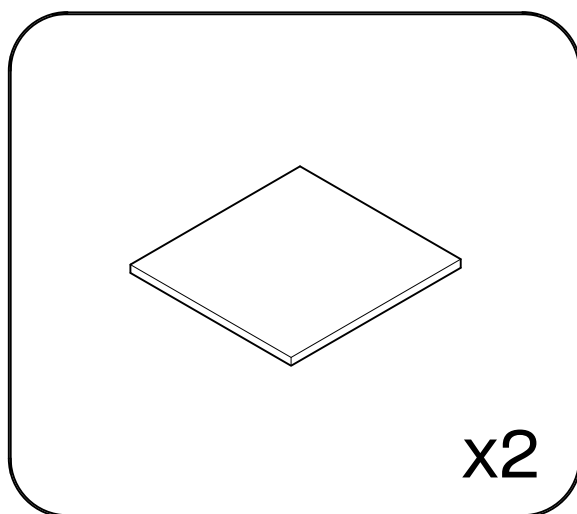

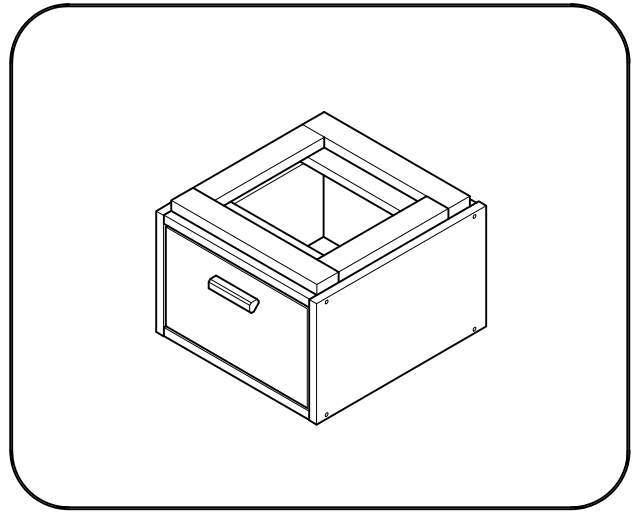

Libe módulo cajón 39x30



BH23-004

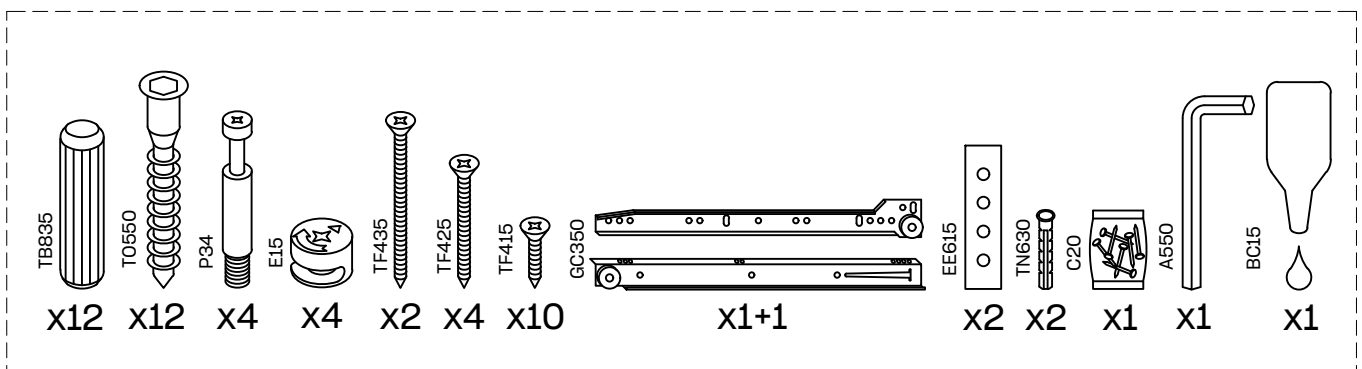

**1**  x 4  x 1+1

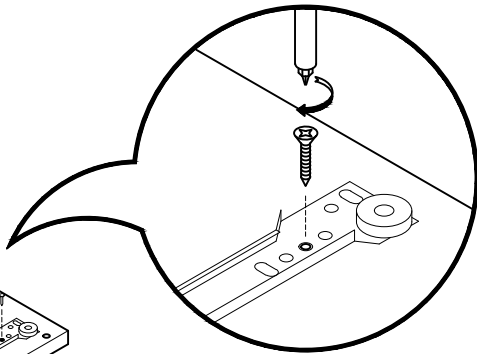

**2**  x 8

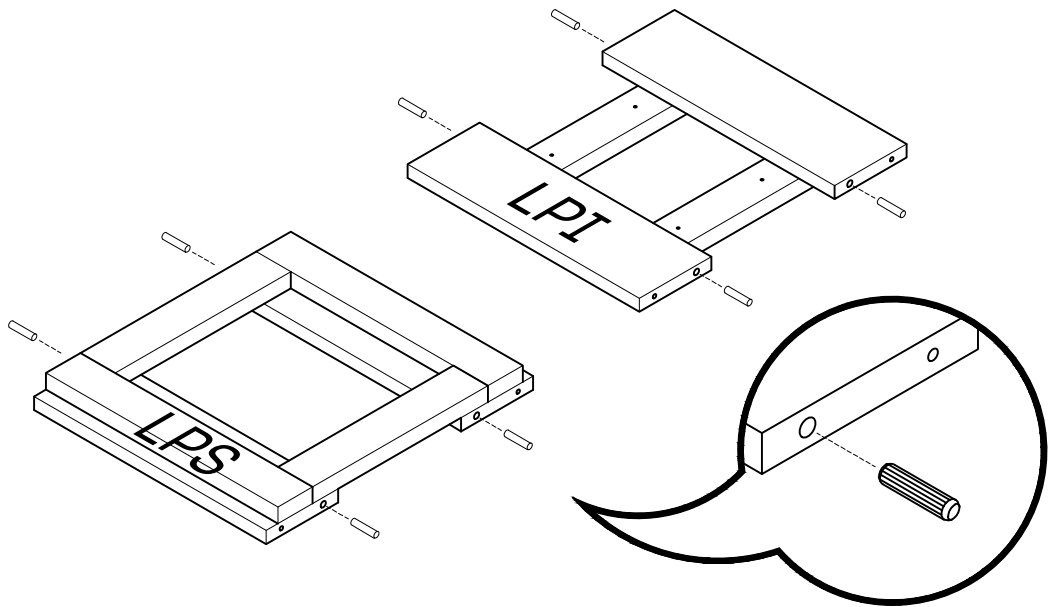

**L U F E**

3  x 8



L U F E

4





5  x 1

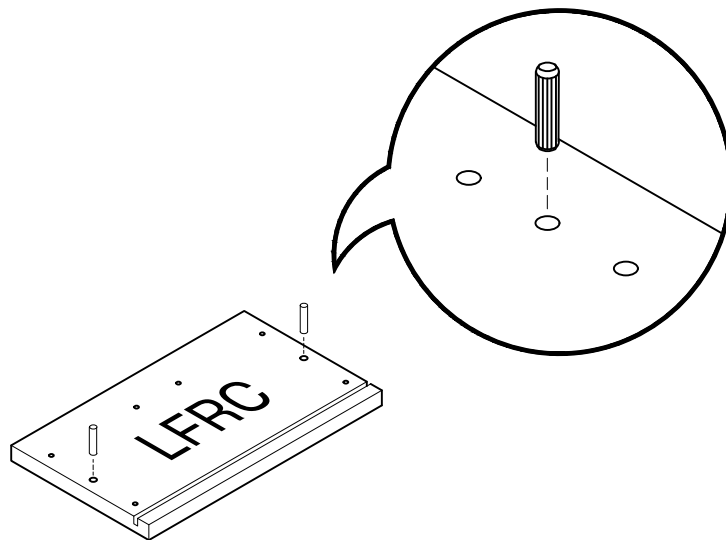

L U F E

6  x 2



7  x 4



L U F E

8



9  x 4



L U F E



# 10



# 11



x 4



# LUFE

12  x 2



13  x 4  x 1+1



L U F E

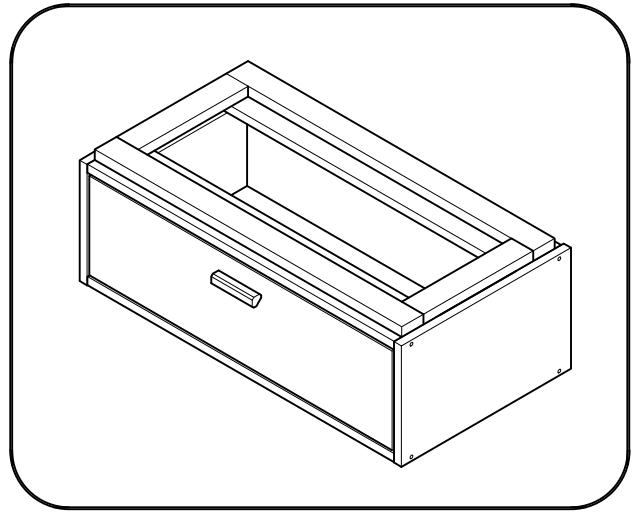

### Libe módulo cajón 78x30

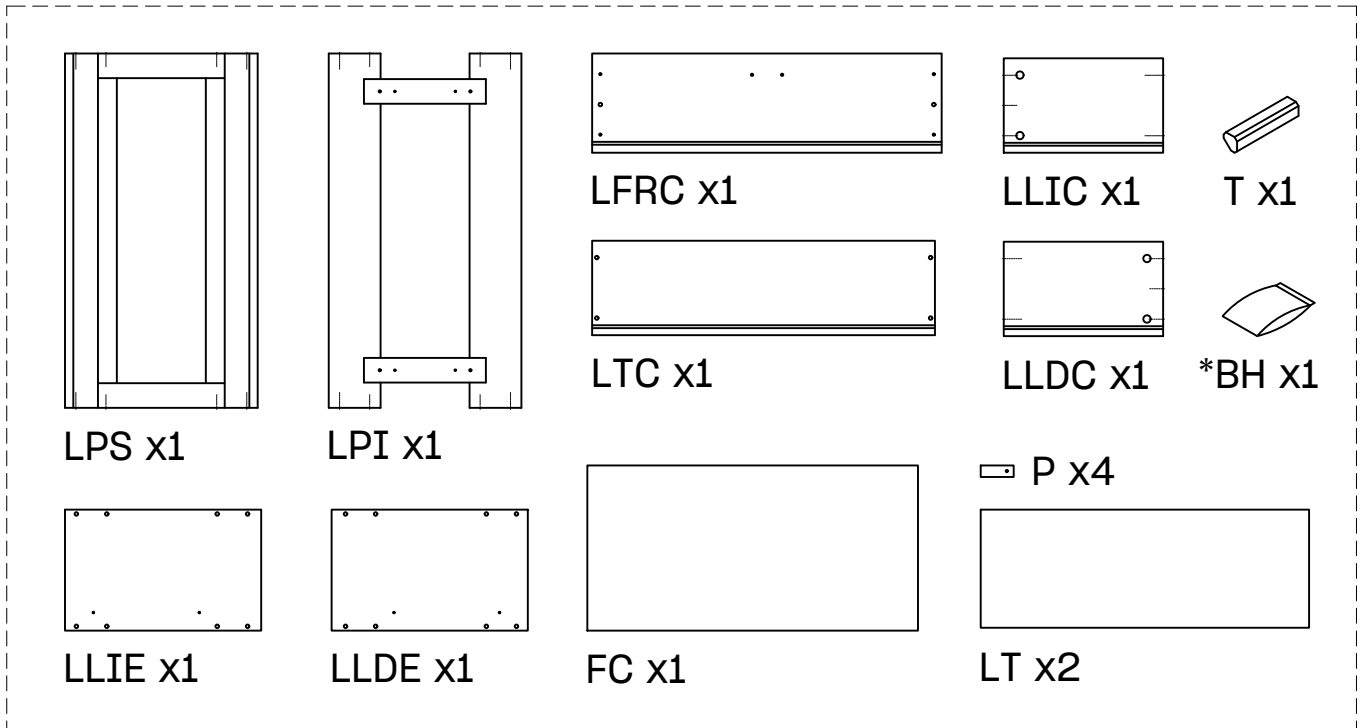

### BH23-004

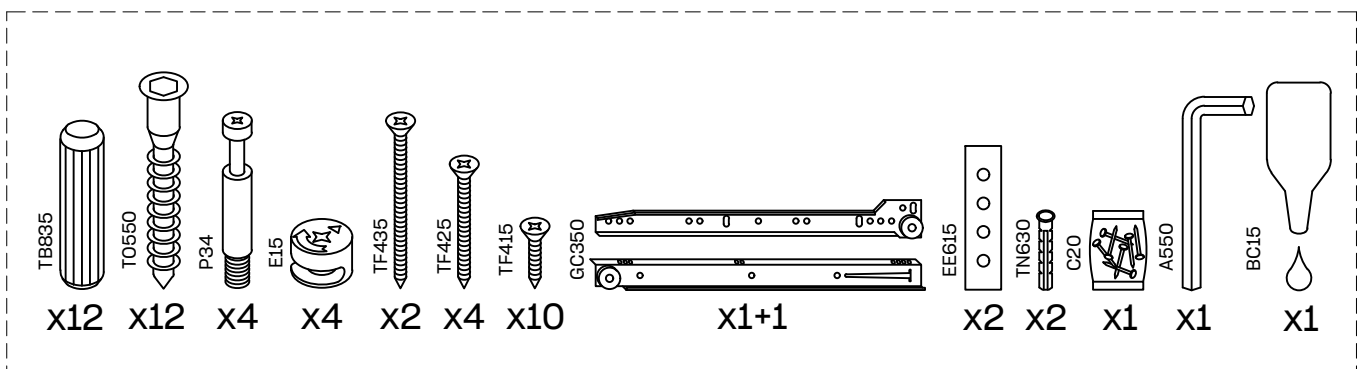

14  x 4  x 1+1

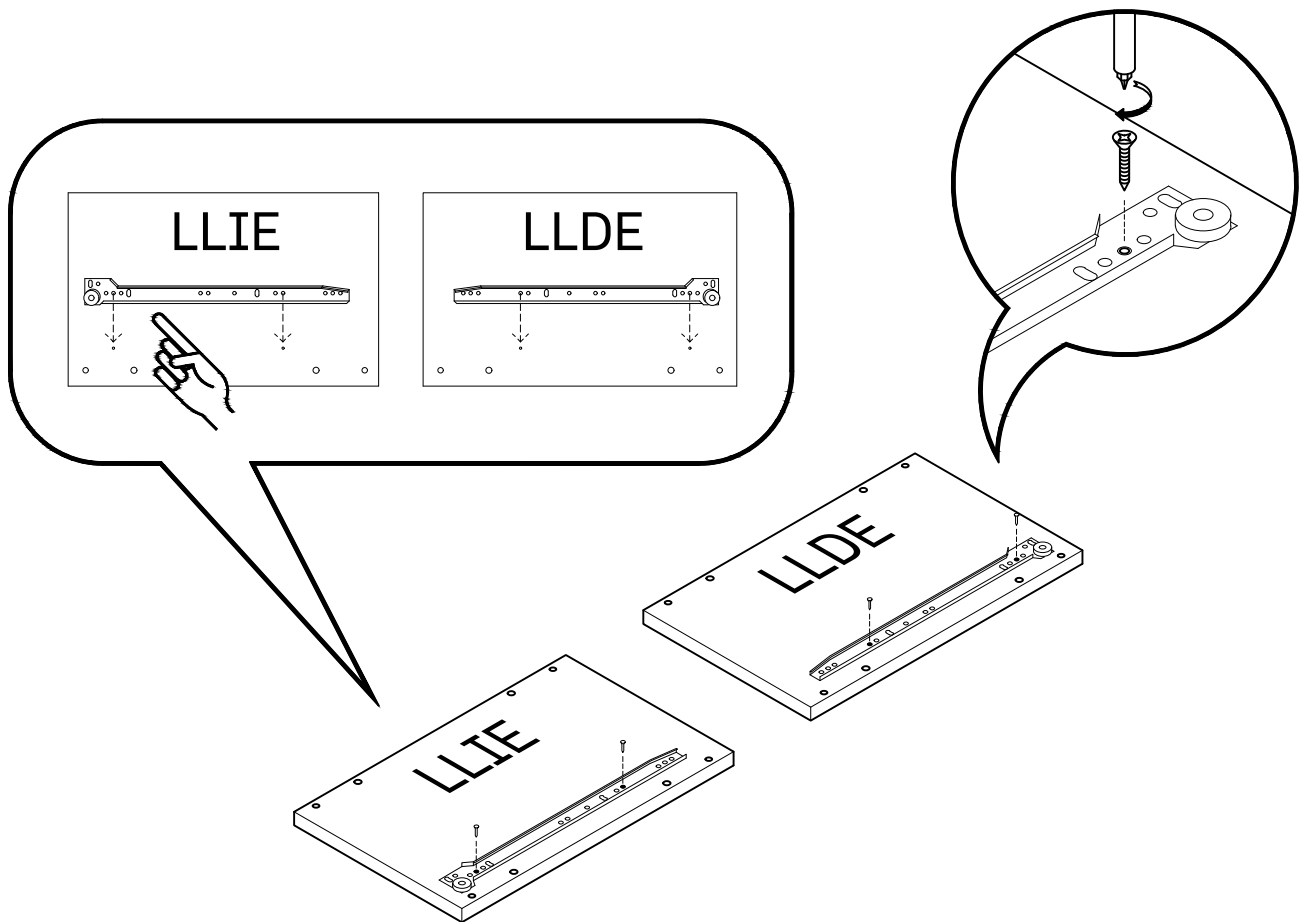

15  x 8



L U F E

16

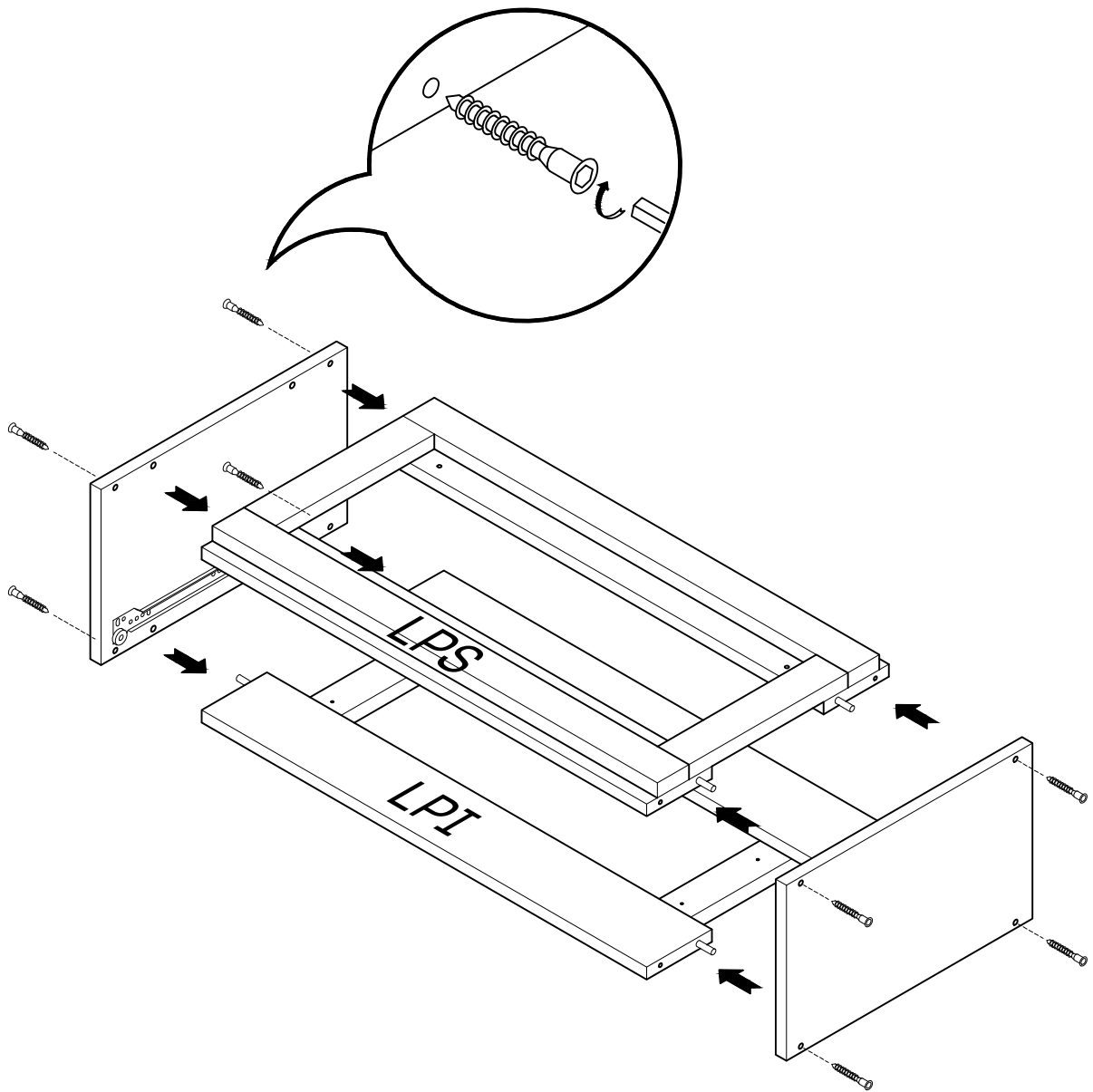

L U F E

# 17



# 18





x 1

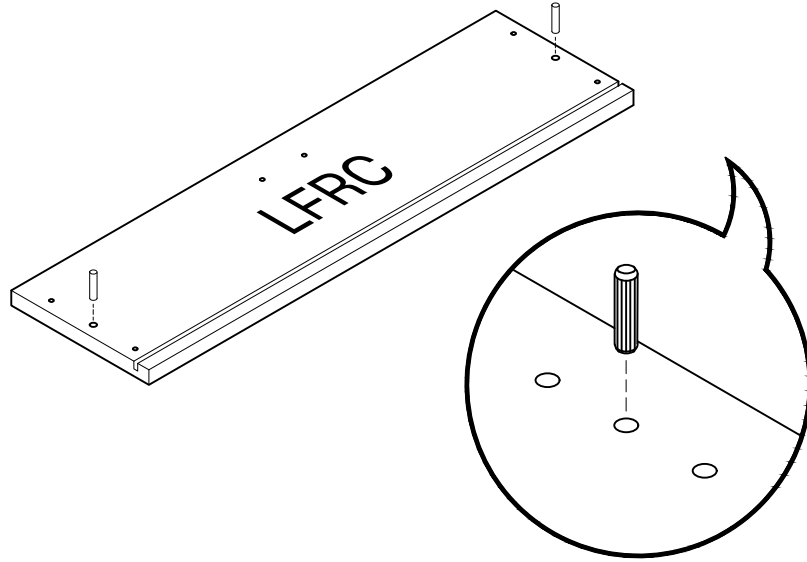

# L U F E

19  x 2



20  x 4

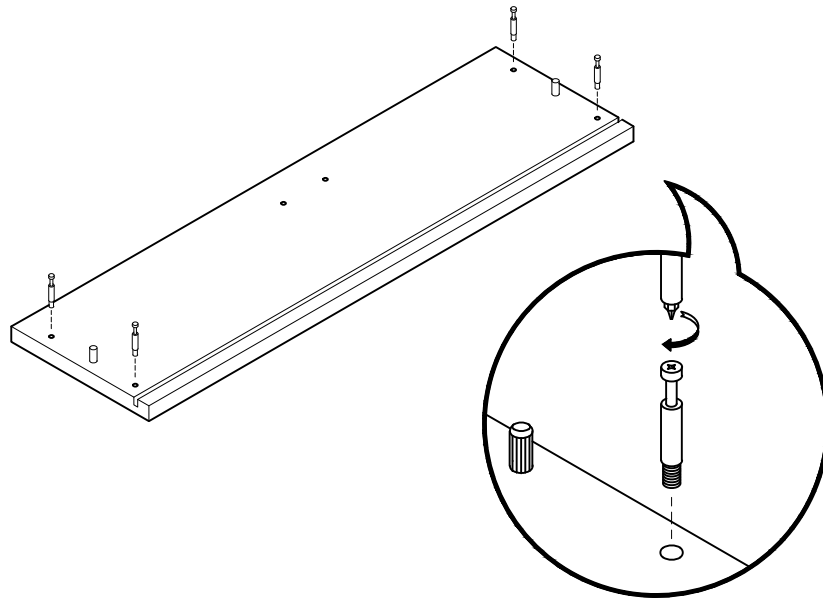

L U F E

# 21

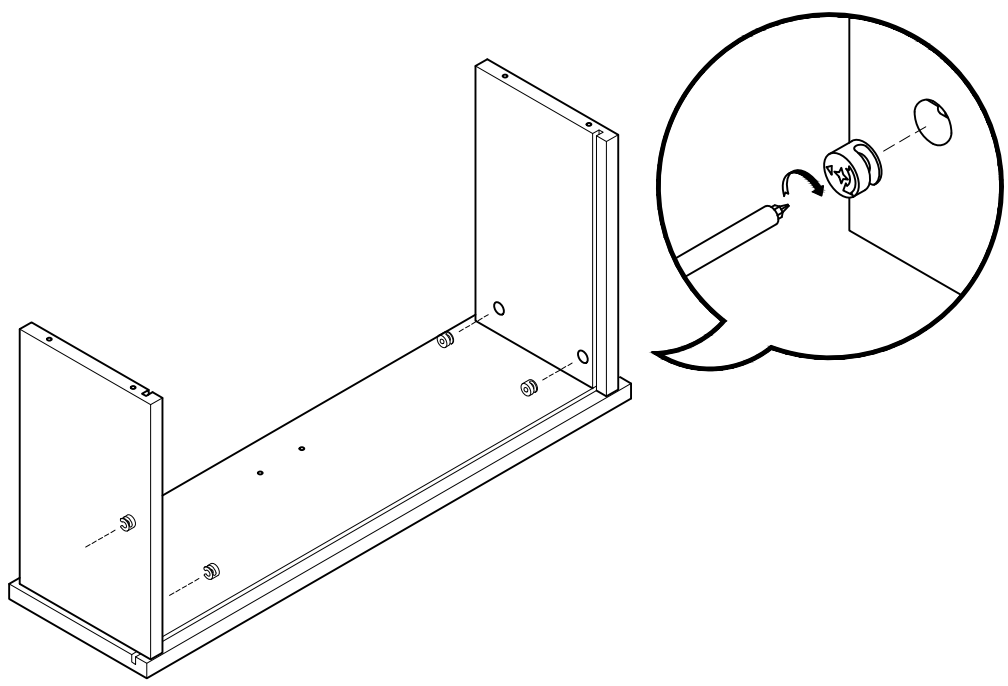

# 22

 x 4

# L U F E



23



24  x 4

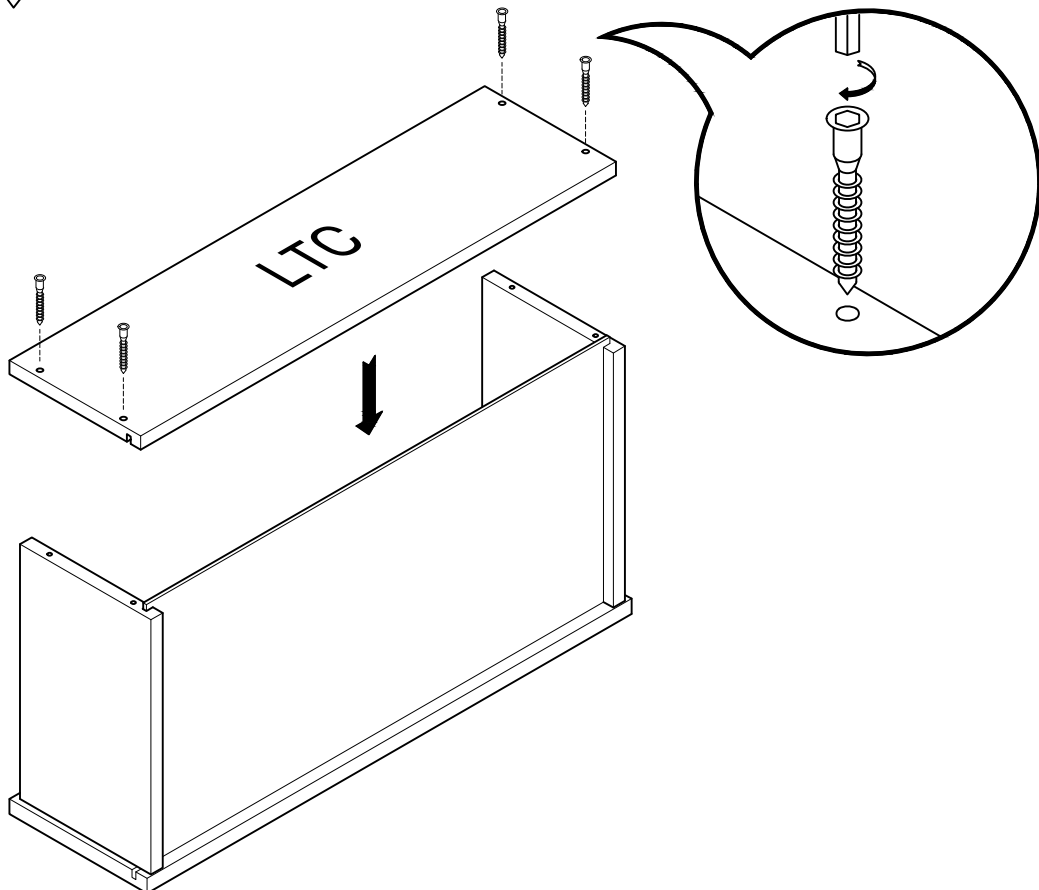

L U F E

25  x 2

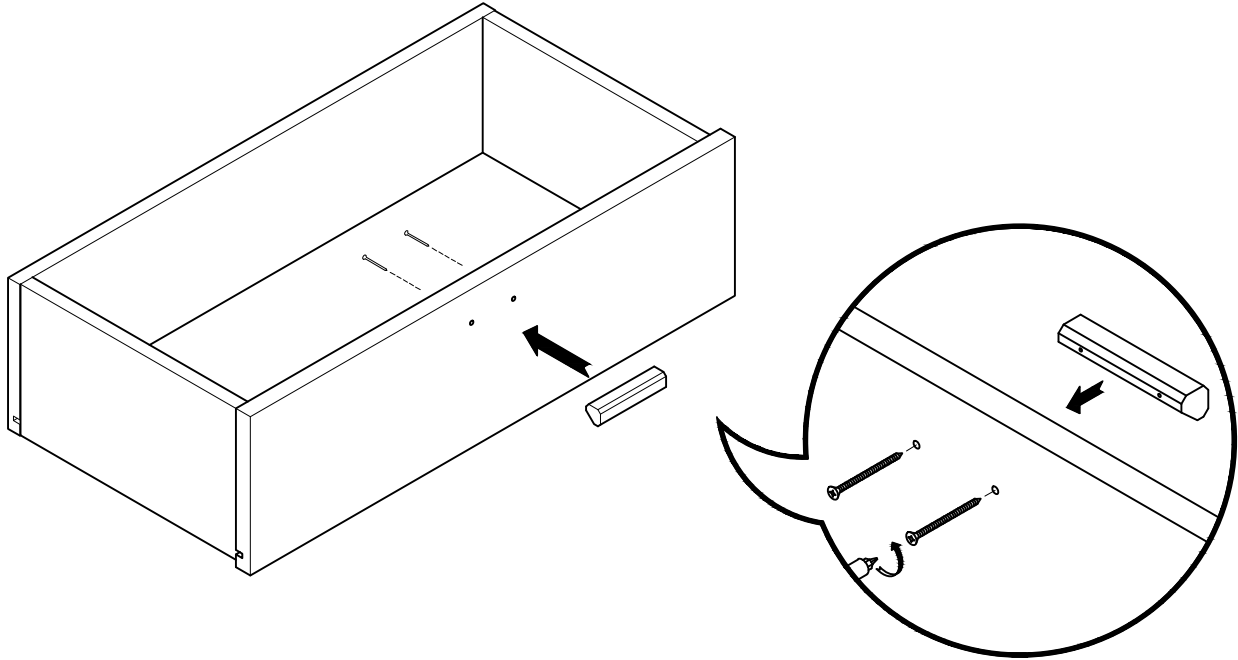

26  x 4  x 1+1

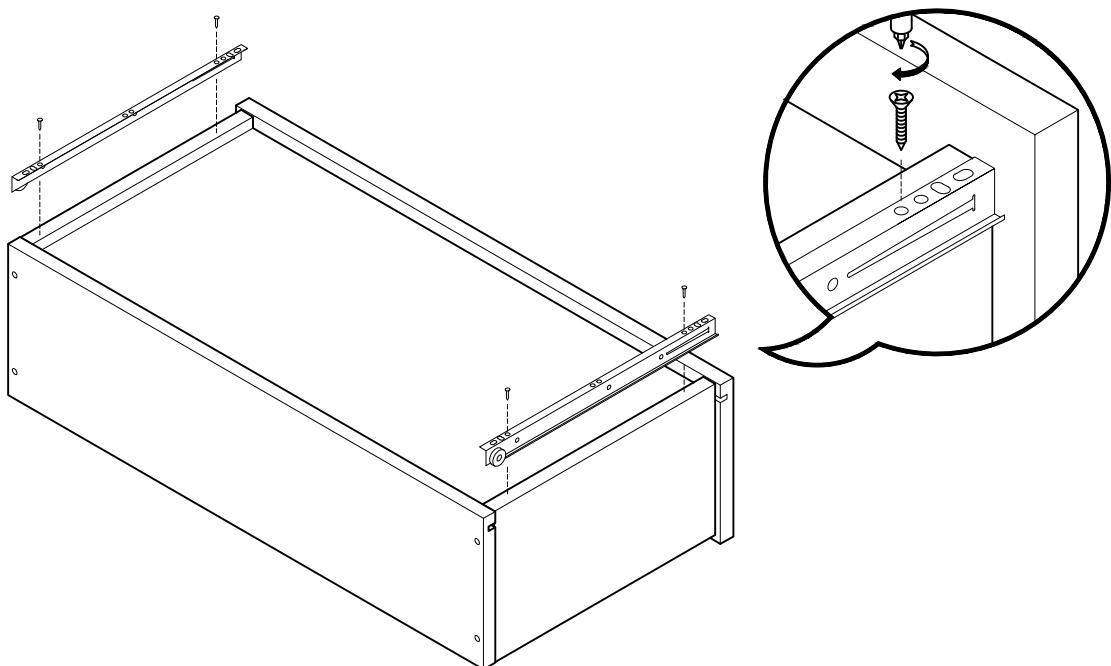

L U F E

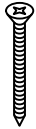
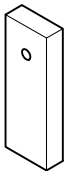
27  x 2  x 2

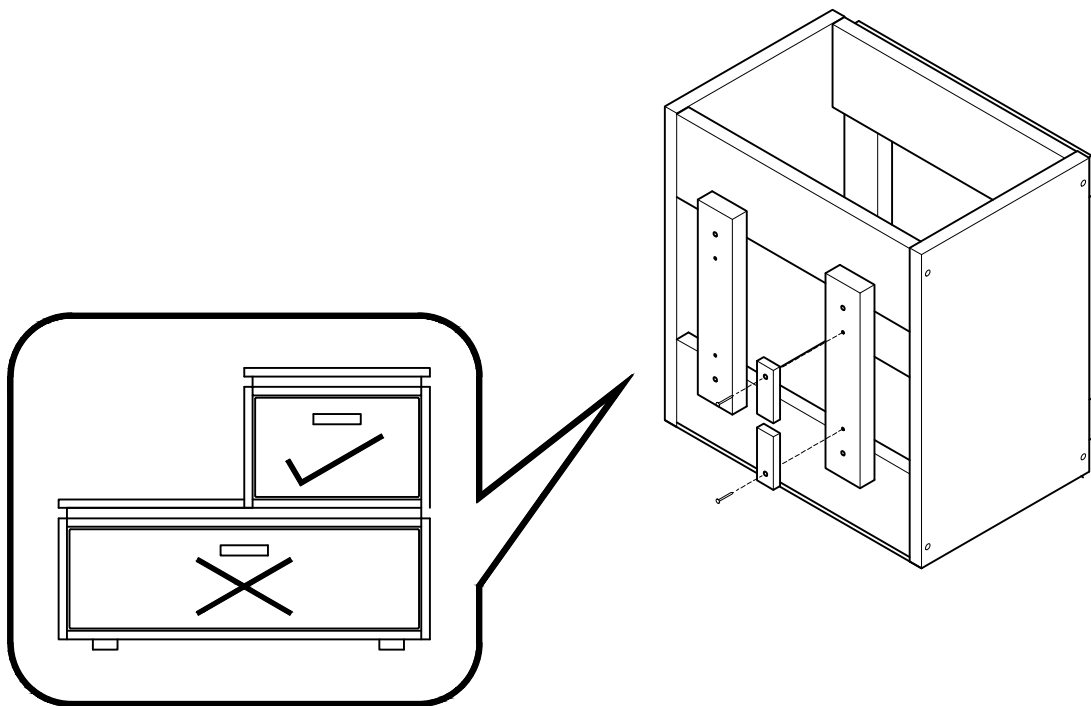
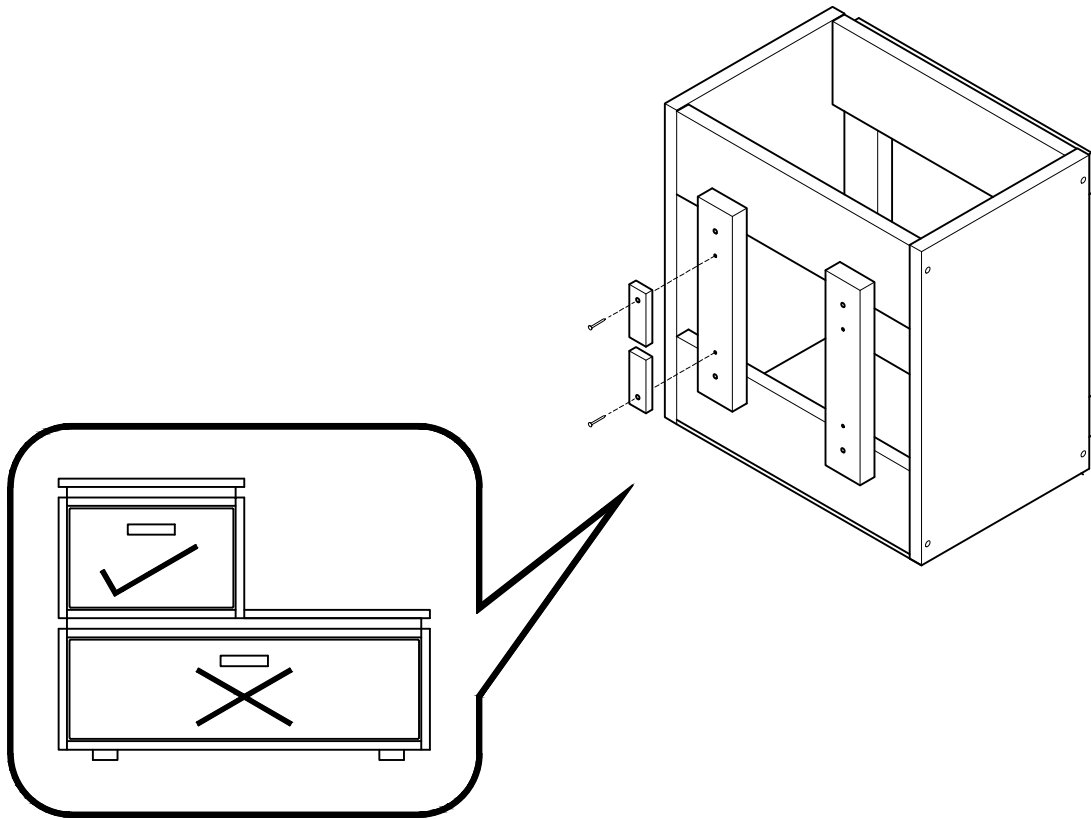

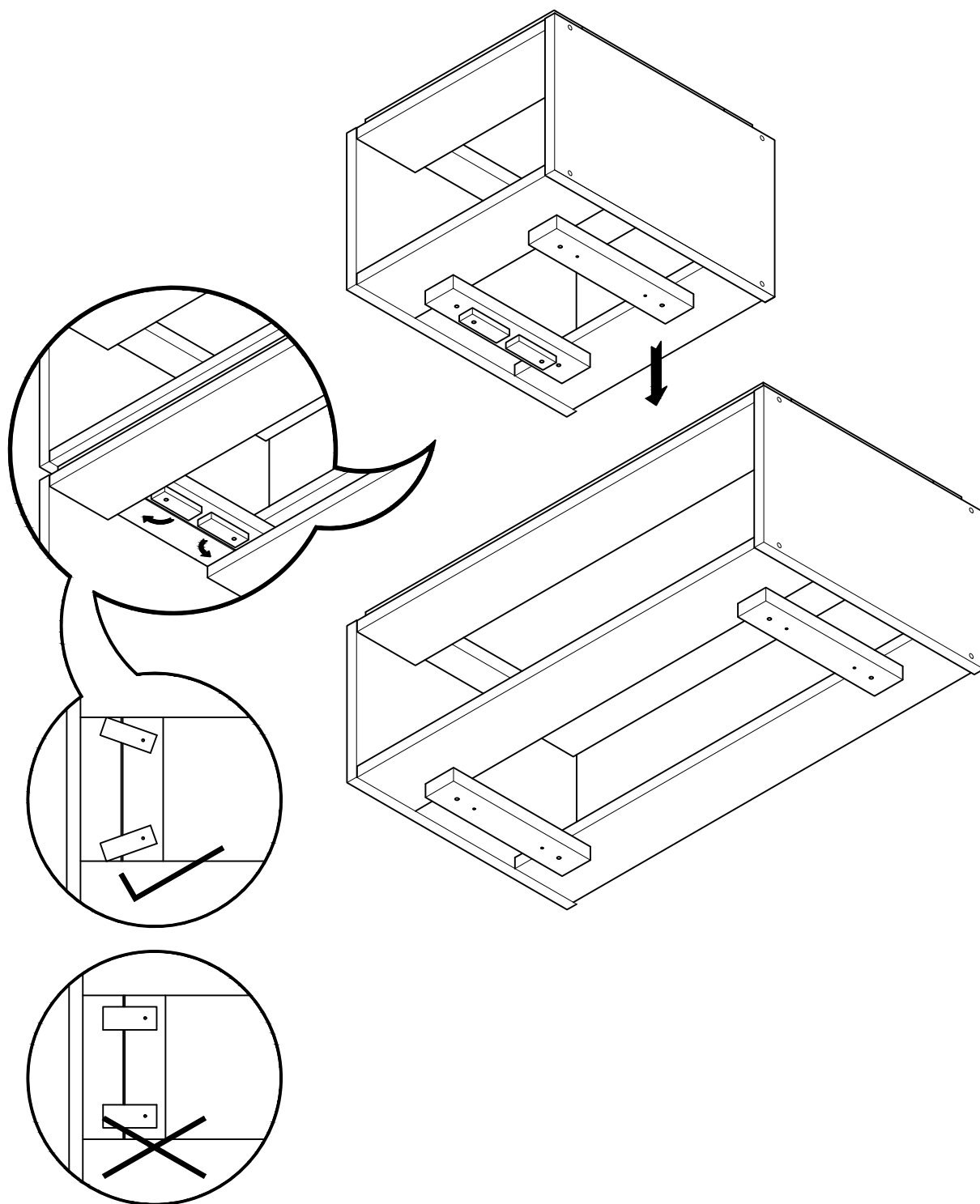

L U F E

# 28



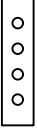

# L U F E

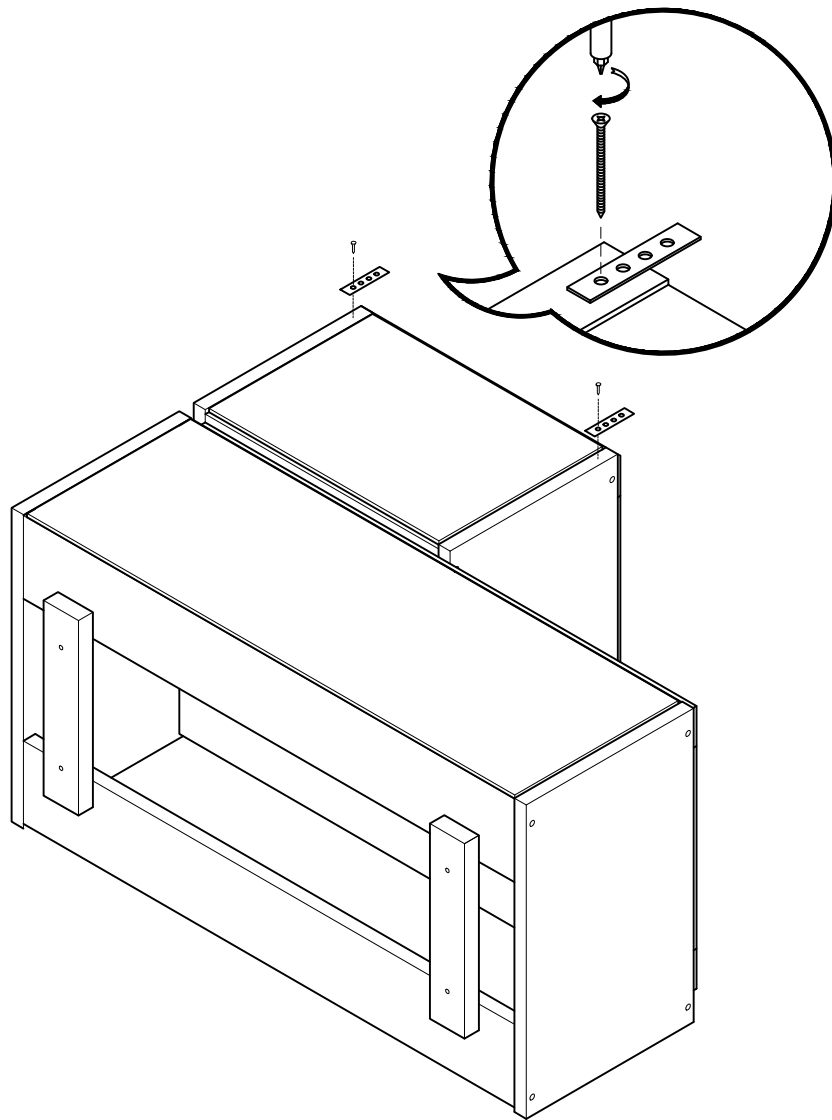
28  x 2  x 2

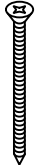

L U F E

29  x 2  x 2

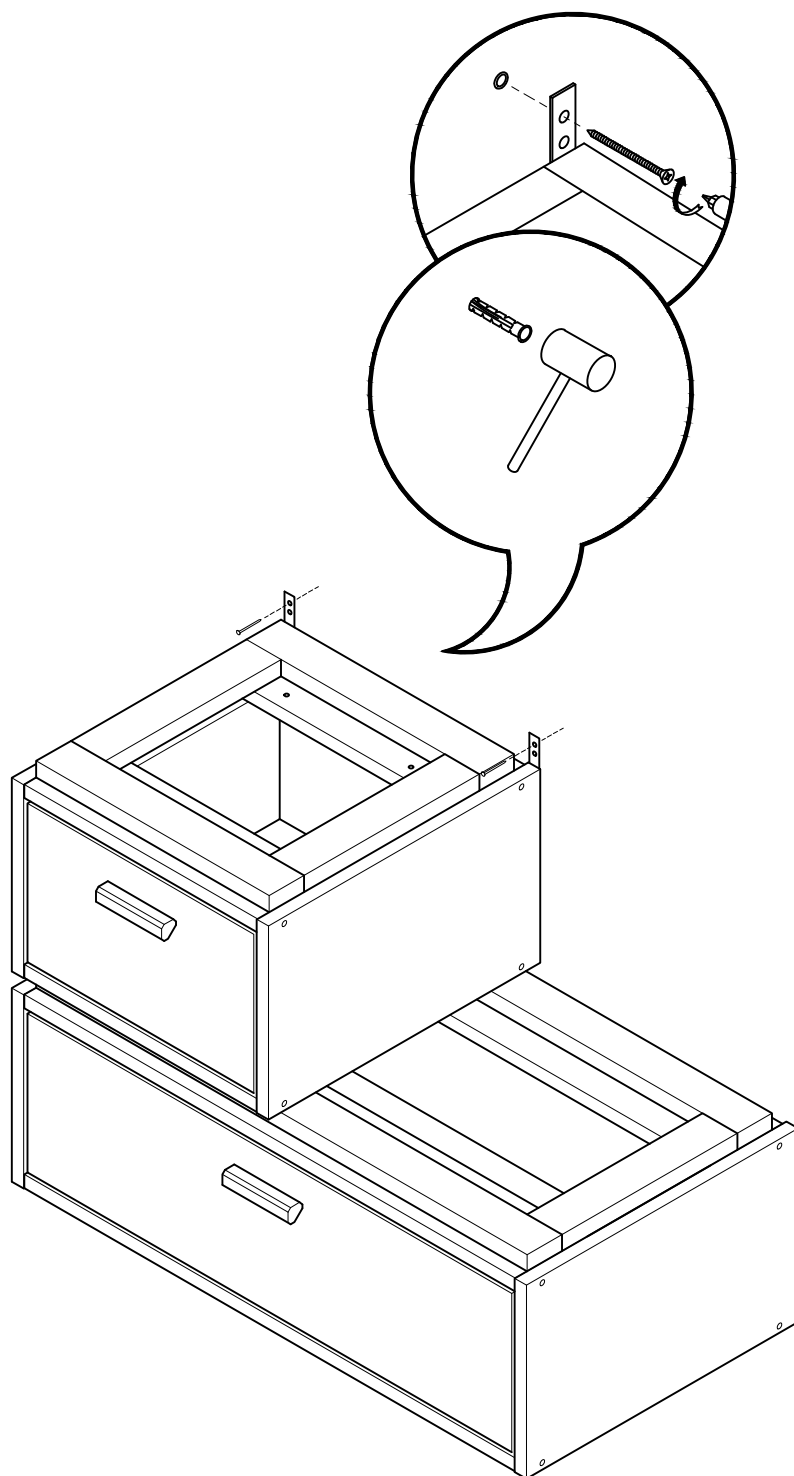

Imprescindible anclar a la pared.  
Ancrage au mur nécessaire.  
A fixação à parede é essencial.

L U F E

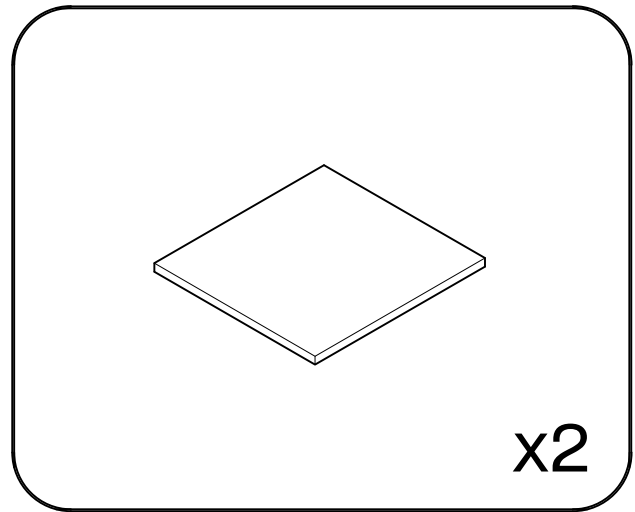

Libe encimera 39 x2

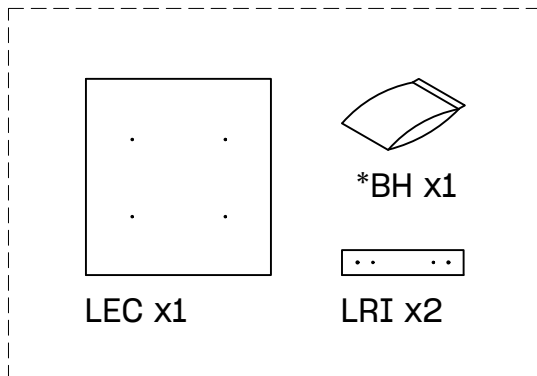

BH20-036 x2

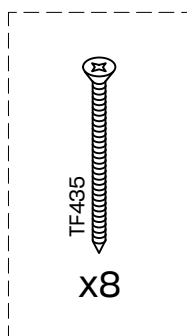

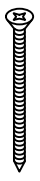
30  x 4

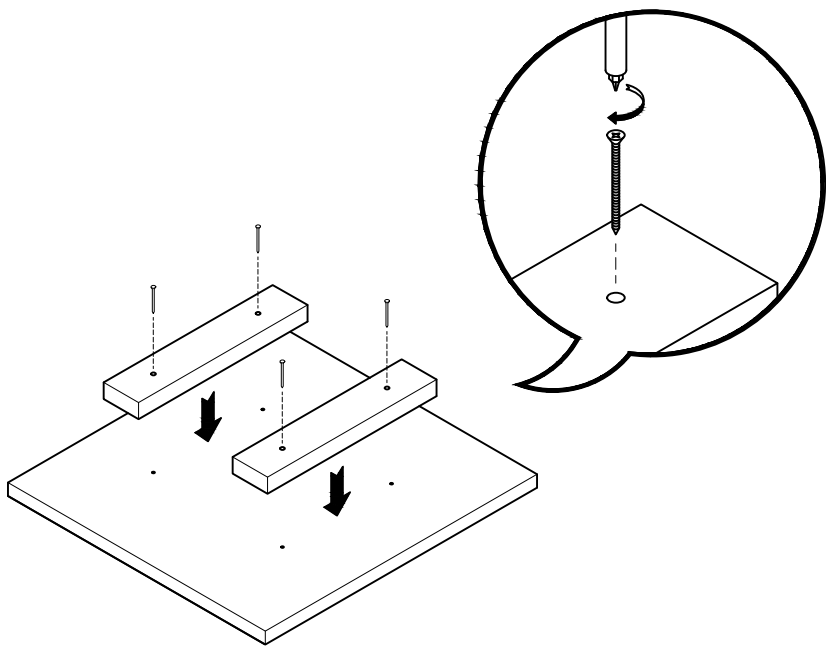

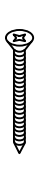
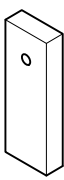
31  x 4  x 4

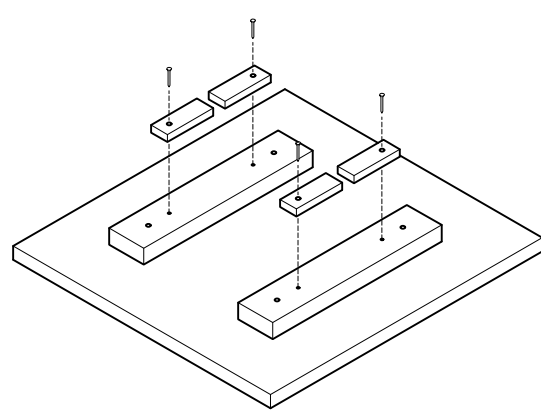

L U F E



# 32

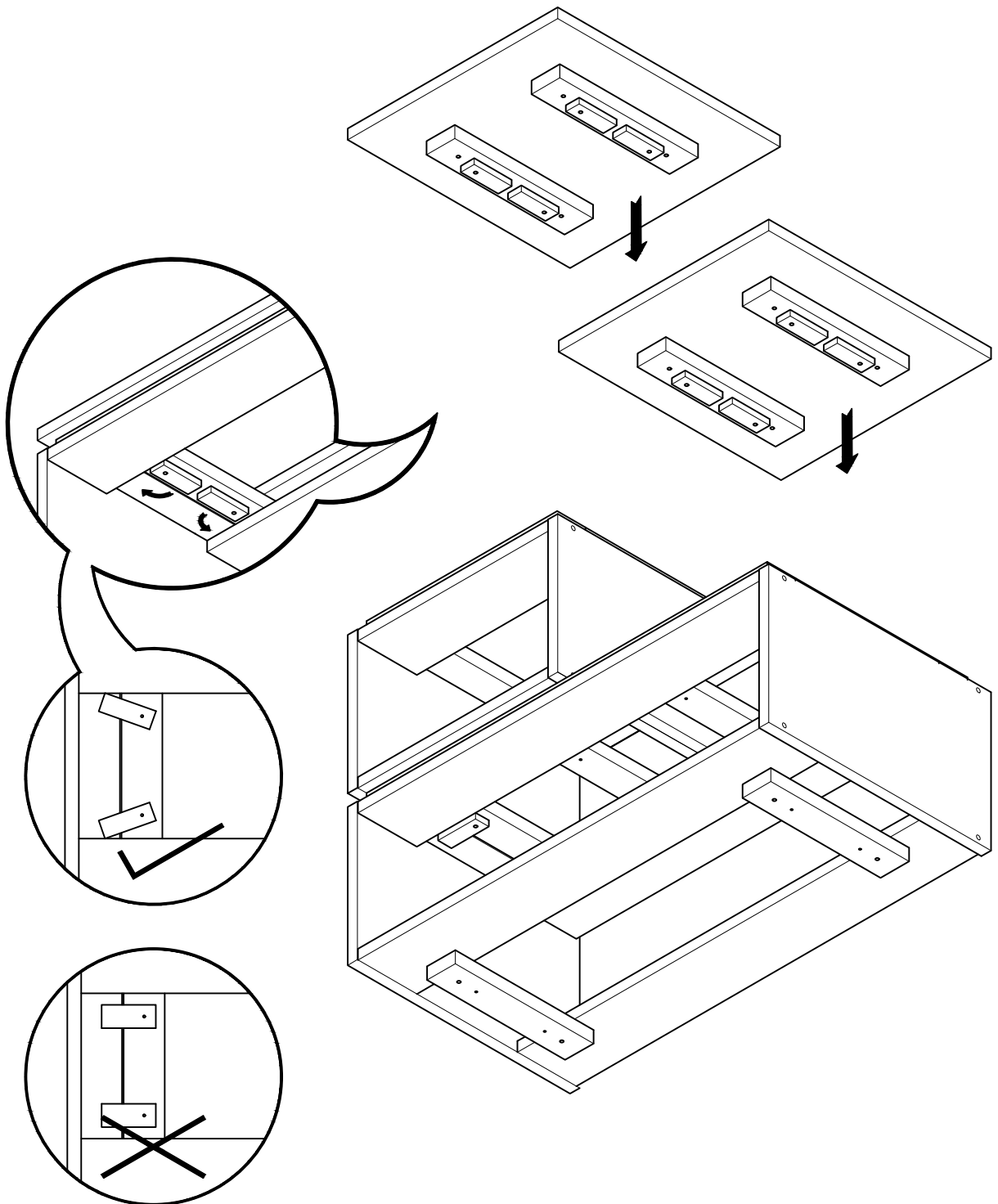

# L U F E

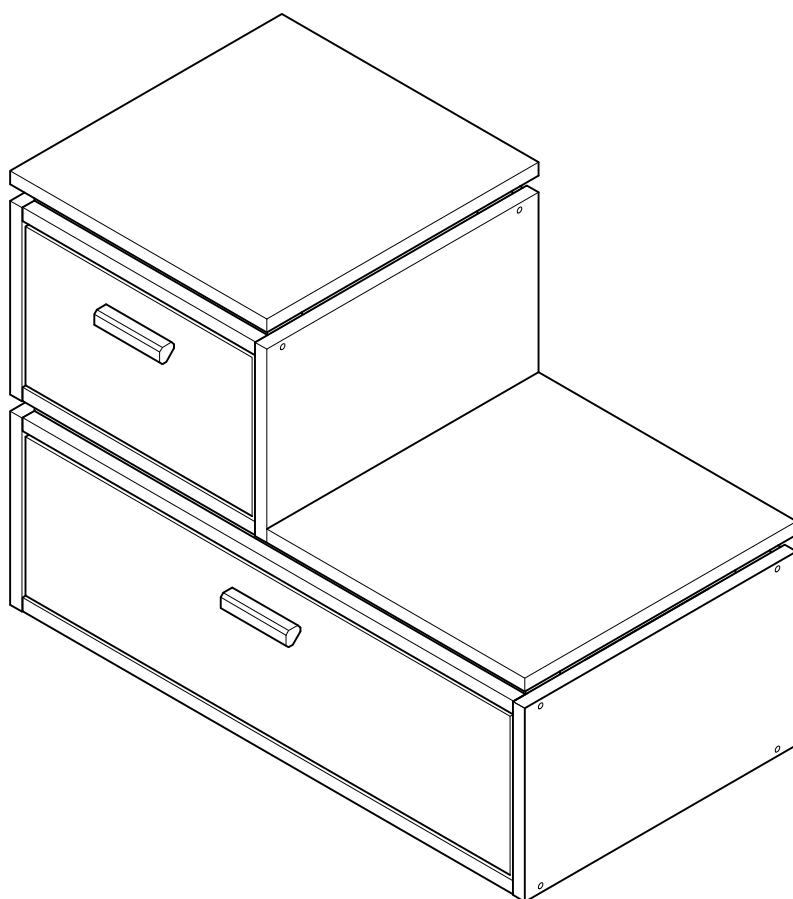

**L U F E**

ESPAÑA  
muebleslufe.com  
@muebleslufe

FRANCE  
meubleslufe.fr  
@lufefrance

PORTUGAL  
moveislufe.pt  
@lufeportugal

---

**L U F E**

TODOLUFE S.L.  
Pol. Ind. Etxezarreta 9  
20749 Aizarnazabal (Gipuzkoa)

(+34) 943 810 795  
info@muebleslufe.com